

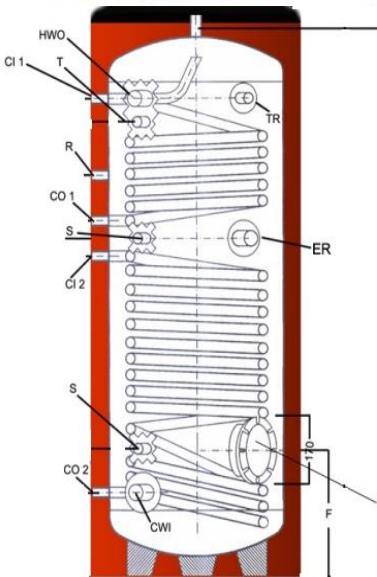

DOUBLE SERPENTINE WATER HEATER



That are produced according to European Standard (EN 12897), are double enamel coated and they are used especially in villas, hotels, restraunts, factories. They can be used also every buildings that need hot water. They are used by connecting to a boiler and a solar connector at the same time.



CWI	Cold Water Input
HWO	Hot Water Output
CI	Heat Ex-Changer Input
CO	Heat Ex-Changer Output
R	Re-Circulation
Aⁿ	Anode
S	Sensor Connection Point
TR	Thermometer Connection Point
F	Boiler Cleaning Flange
ER	Heating Element Connection Flange

Technical Features

- Capacity between 160 – 5000 lt
- Contact with water are double enamel coated.
- Capacity between 160 - 600 polyurethane insulation
- Capacity between 800 - 5000 special sponge insulation
- Capacity between 160 – 600 electrostatics powder painted cover on galvanized plate
- Capacity between 800 – 5000 special winlex cover
- Cathodic protect
- High Efficiency
- Electrical resistance (optional)
- Esthetic apperance
- 10 bar operating pressure

CAPACITY TABLE												
Water Inlet 10 C Hot Water Outlet 60 C ,heating fluid inlet 80 C(for radiator)												
MODEL	DCSB 162	DCSB 202	DCSB 352	DCSB 502	DCSB 602	DCSB 802	DCSB 1002	DCSB 1502	DCSB 2002	DCSB 3002	DCSB 4002	DCSB 5002
CAPACITY	160 lt	200 lt	350 lt	500 lt	600 lt	800 lt	1000 lt	1500 lt	2000 lt	3000 lt	4000 lt	5000 lt
Flow (lt/h)	570	735	845	1400	1400	1550	1550	1850	1850	2885	3503	4120
Water Inlet 10 C Hot Water Outlet 60 C ,heating fluid inlet 80 C(for radiator)												
MODEL	DCSB 162	DCSB 202	DCSB 352	DCSB 502	DCSB 602	DCSB 802	DCSB 1002	DCSB 1502	DCSB 2002	DCSB 3002	DCSB 4002	DCSB 5002
CAPACITY	160 lt	200 lt	350 lt	500 lt	600 lt	800 lt	1000 lt	1500 lt	2000 lt	3000 lt	4000 lt	5000 lt
Flow (lt/h)	325	400	740	778	778	945	945	1320	1320	2060	2501	2942
Water Inlet 10 C Hot Water Outlet 45 C for steam operating												
MODEL	DCSB 162	DCSB 202	DCSB 352	DCSB 502	DCSB 602	DCSB 802	DCSB 1002	DCSB 1502	DCSB 2002	DCSB 3002	DCSB 4002	DCSB 5002
CAPACITY	160 lt	200 lt	350 lt	500 lt	600 lt	800 lt	1000 lt	1500 lt	2000 lt	3000 lt	4000 lt	5000 lt
0,5 ATU Hot Water Capacity (lt)	935	1048	1535	1960	1960	2110	2110	2980	2980	4640	5634	6628
1 ATU Hot Water Capacity (lt)	1050	1455	1740	2485	2485	2690	2690	3800	3800	5910	7160	8442
DIMENSION TABLE												
MODEL	DCSB 162	DCSB 202	DCSB 352	DCSB 502	DCSB 602	DCSB 802	DCSB 1002	DCSB 1502	DCSB 2002	DCSB 3002	DCSB 4002	DCSB 5002
CAPACITY	160 lt	200 lt	350 lt	500 lt	600 lt	800 lt	1000 lt	1500 lt	2000 lt	3000 lt	4000 lt	5000 lt
DIAMETER	586	586	756	756	756	910	1010	1120	1260	1460	1660	1660
HEIGHT (mm)	1050	1250	1270	1720	1970	2100	2130	2420	2450	2750	2480	2980
HEATING INLET OUTLET (inch)	1 1/4"	1 1/4"	1 1/4"	1 1/4"	1 1/4"	1 1/4"	1 1/4"	1 1/4"	1 1/4"	1 1/4"	1 1/2"	1 1/2"
COLLEKTOR INLET OUTLET (inch)	1 1/4"	1 1/4"	1 1/4"	1 1/4"	1 1/4"	1 1/4"	1 1/4"	1 1/4"	1 1/4"	1 1/4"	2 1/2"	1 1/2"
WATER INLET (inch) HOT WATER OUTLET (inch)	3/4"	3/4"	1"	1"	1"	1 1/4"	1 1/4"	1 1/2"	1 1/2"	2"	2 1/2"	2 1/2"
CIRCULATION (inch)	3/4"	3/4"	1"	1"	1"	1 1/4"	1 1/4"	1 1/2"	1 1/2"	2"	2"	2"
SERPENTINE SURFACE (m2) (Sun Collektor)	0,74	0,81	1,2	2,19	2,19	3,08	3,08	4,97	4,97	7	8,5	10
SERPENTINE SURFACE (m2) (Heater)	0,59	0,74	1	1,39	1,39	1,54	1,54	2,18	2,18	3,4	4,25	5,01
WEIGHT (kg)	102	114	143	198	227	332	391	447	582	895	1250	1440



Diko Electrical Equipments Ind. and Trade Corp.

IMES Sanayi Sitesi B Blok. 206 Sok. No:6 ZIP Code:37775

Dudullu - ISTANBUL / TURKEY

Phone:+90216 3142626 Fax:+90216 4204901

www.diko.com.tr

info@diko.com.tr

